

DESIGN

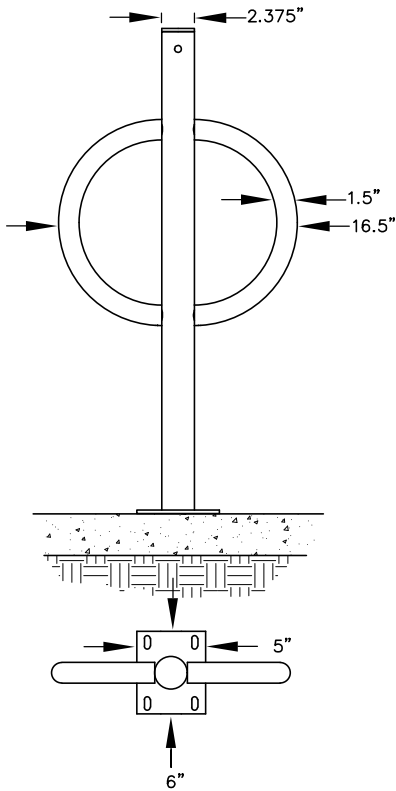

ANCHOR INSTALLATION

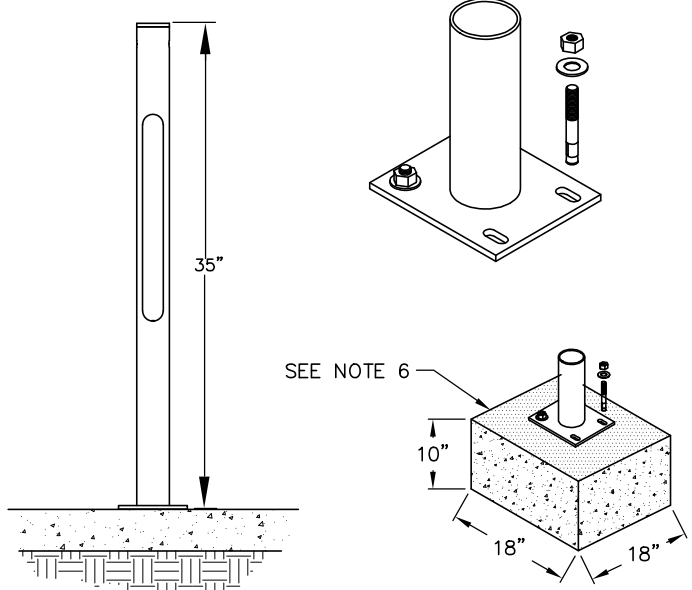

NOTES:

1. SHOP DRAWINGS SHALL BE SUBMITTED TO THE ENGINEER A MINIMUM OF 3 WEEKS PRIOR TO INSTALLATION
2. BIKE RACK SHALL BE HOT-DIPPED GALVANIZED WITH A BLACK FINISH
3. TAMPER RESISTANT BOLTS ARE REQUIRED FOR ANCHOR INSTALLATION
4. IF NOT SUPPLIED BY THE RACK MANUFACTURER, ANCHORING BOLTS (SPECIFICATIONS) SHALL BE SUBMITTED TO THE ENGINEER FOR APPROVAL PRIOR TO INSTALLATION (STAINLESS STEEL BOLT ARE REQUIRED)
5. APPROPRIATE CLEAR ZONES SHALL BE CONFIRMED PRIOR TO INSTALLATION
6. FOOTING INSTALLATION METHOD TO BE USED WHEN RACK IS NOT INSTALLED WITHIN A CONCRETE WALK AREA

708 - BIKE RACK (HITCH)

708 - BIKE RACK (HITCH).DWG 9/2016

H:\Cad_Comm\Details Updated\0 - 700 - TRAFFIC complete\708 - Bike Rack (Hitch)

CITY OF BLOOMINGTON MINNESOTA
 1700 W 98TH ST.
 BLOOMINGTON MN 55431
 PHONE (952) 563-8700

**ENGINEERING DIVISION
 PUBLIC WORKS DEPARTMENT**

PLATE NAME:

708 - Bike Rack (Hitch)

LAST REVISED: 9/16/2016

LAST REVISED BY: KBO